



FEATURES

- 3.3V and 5V power supply options
- 250ps propagation delay
- High bandwidth output transitions
- Internal 75K Ω input pull-down resistors
- Replaces SY10/100EL16
- Improved output waveform characteristics
- Available in 8-pin (3x3mm) MSOP and SOIC package

DESCRIPTION

The SY10/100EL16V are differential receivers. The devices are functionally equivalent to the E116 devices, with higher performance capabilities. With output transition times significantly faster than the E116, the EL16V is ideally suited for interfacing with high-frequency sources.

The EL16V provides a VBB output for either single-ended use or as a DC bias for AC coupling to the device. The VBB pin should be used only as a bias for the EL16V as its current sink/source capability is limited. Whenever used, the VBB pin should be bypassed to ground via a 0.01 μ F capacitor.

Under open input conditions (pulled to VEE), internal input clamps will force the Q output LOW.

PIN NAMES

Pin	Function
D	Data Inputs
Q	Data Outputs
VBB	Reference Voltage Output

PACKAGE/ORDERING INFORMATION

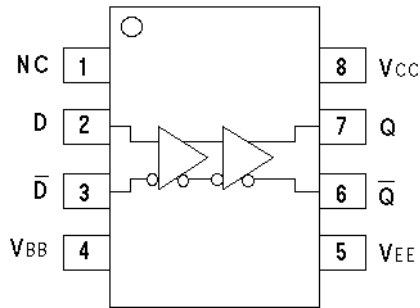

8-Pin MSOP (K8-1)
8-Pin SOIC (Z8-1)

Ordering Information⁽¹⁾

Part Number	Package Type	Operating Range	Package Marking	Lead Finish
SY10EL16VKC	K8-1	Commercial	HEL16V	Sn-Pb
SY10EL16VKCTR ⁽²⁾	K8-1	Commercial	HEL16V	Sn-Pb
SY100EL16VKC	K8-1	Commercial	XEL16V	Sn-Pb
SY100EL16VKCTR ⁽²⁾	K8-1	Commercial	XEL16V	Sn-Pb
SY10EL16VZC	Z8-1	Commercial	HEL16V	Sn-Pb
SY10EL16VZCTR ⁽²⁾	Z8-1	Commercial	XEL16V	Sn-Pb
SY100EL16VZC	Z8-1	Commercial	HEL16V	Sn-Pb
SY100EL16VZCTR ⁽²⁾	Z8-1	Commercial	XEL16V	Sn-Pb
SY10EL16VKI	K8-1	Industrial	HEL16V	Sn-Pb
SY10EL16VKITR ⁽²⁾	K8-1	Industrial	HEL16V	Sn-Pb
SY100EL16VKI	K8-1	Industrial	XEL16V	Sn-Pb
SY100EL16VKITR ⁽²⁾	K8-1	Industrial	XEL16V	Sn-Pb
SY10EL16VZI	Z8-1	Industrial	HEL16V	Sn-Pb
SY10EL16VZITR ⁽²⁾	Z8-1	Industrial	XEL16V	Sn-Pb
SY100EL16VZI	Z8-1	Industrial	HEL16V	Sn-Pb
SY100EL16VZITR ⁽²⁾	Z8-1	Industrial	XEL16V	Sn-Pb
SY10EL16VKG ⁽³⁾	K8-1	Industrial	H16V with Pb-Free bar-line indicator	Pb-Free NiPdAu
SY10EL16VKGTR ^(2, 3)	K8-1	Industrial	H16V with Pb-Free bar-line indicator	Pb-Free NiPdAu
SY100EL16VKG ⁽³⁾	K8-1	Industrial	X16V with Pb-Free bar-line indicator	Pb-Free NiPdAu
SY100EL16VKGTR ^(2, 3)	K8-1	Industrial	X16V with Pb-Free bar-line indicator	Pb-Free NiPdAu
SY10EL16VZG ⁽³⁾	Z8-1	Industrial	HEL16V with Pb-Free bar-line indicator	Pb-Free NiPdAu
SY10EL16VZGTR ^(2, 3)	Z8-1	Industrial	HEL16V with Pb-Free bar-line indicator	Pb-Free NiPdAu
SY100EL16VZG ⁽²⁾	Z8-1	Industrial	XEL16V with Pb-Free bar-line indicator	Pb-Free NiPdAu
SY100EL16VZGTR ^(2, 3)	Z8-1	Industrial	XEL16V with Pb-Free bar-line indicator	Pb-Free NiPdAu

Notes:

1. Contact factory for die availability. Dice are guaranteed at T_A = 25°C, DC Electricals only.
2. Tape and Reel.
3. Pb-Free package is recommended for new designs.

PRODUCT/PROCESS INFORMATION

Process:	Bipolar
ESD Rating:	Per Mil Std. 883 Human Body Model, >2.0kV (all pins).

ABSOLUTE MAXIMUM RATINGS⁽¹⁾

Symbol	Rating	Value	Unit
V _{CC}	Power Supply Voltage (V _{EE} = 0)	+6.0 to 0	V
V _{EE}	Power Supply Voltage (V _{CC} = 0)	-6.0 to 0	V
V _{IN}	Input Voltage (V _{CC} = 0V, V _{IN} not more negative than V _{EE}) Input Voltage (V _{EE} = 0V, V _{IN} not more positive than V _{CC})	-6.0 to 0 +6.0 to 0	V V
I _{OUT}	Output Current -Continuous -Surge	50 100	mA
T _{LEAD}	Lead Temperature Range (soldering, 20sec.)	+260	°C
T _A	Operating Temperature Range	-40 to +85	°C
T _{store}	Storage Temperature Range	-65 to +150	°C
θ _{JA}	Thermal Resistance (Junction-to-Ambient) -Still Air -500lfpm	160 109	°C/W °C/W
θ _{JC}	Thermal Resistance (Junction-to-Case)	39	°C/W
ESD	Mil Std. 883 Human Body Model, All Pins	>2.0k	V

Note 1. Permanent device damage may occur if absolute maximum ratings are exceeded. This is a stress rating only and functional operation is not implied at conditions other than those detailed in the operational sections of this data sheet. Exposure to absolute maximum rating conditions for extended periods may affect device reliability.

DC ELECTRICAL CHARACTERISTICS^(1, 2)

V_{EE} = V_{EE} (Min.) to V_{EE} (Max.); V_{CC} = GND

Symbol	Parameter	T _A = -40°C			T _A = 0°C			T _A = +25°C			T _A = +85°C			Unit
		Min.	Typ.	Max.	Min.	Typ.	Max.	Min.	Typ.	Max.	Min.	Typ.	Max.	
I _{EE}	Power Supply Current													mA
	10EL	—	18	22	9	18	22	9	18	22	9	18	22	
	100EL	—	18	22	9	18	22	9	18	22	9	21	26	
V _{BB}	Output Reference Voltage													V
	10EL	-1.43	—	-1.30	-1.38	—	-1.27	-1.35	—	-1.25	-1.31	—	-1.19	
	100EL	-1.38	—	-1.26	-1.38	—	-1.26	-1.38	—	-1.26	-1.38	—	-1.26	
I _{IH}	Input HIGH Current	—	—	150	—	—	150	—	—	150	—	—	150	µA

Note 1. Parametric values specified at: 10/100EL16V Series: -3.0V to -5.5V.

Note 2. specification for packaged product only.

AC ELECTRICAL CHARACTERISTICS^(1, 5)V_{EE} = V_{EE} (Min.) to V_{EE} (Max.); V_{CC} = GND

Symbol	Parameter	T _A = -40°C			T _A = 0°C			T _A = +25°C			T _A = +85°C			Unit
		Min.	Typ.	Max.	Min.	Typ.	Max.	Min.	Typ.	Max.	Min.	Typ.	Max.	
t _{PD}	Propagation Delay to Output													ps
	D (Diff)	125	250	375	175	250	325	175	250	325	205	280	355	
	D (SE)	75	250	425	125	250	375	125	250	375	155	280	405	
t _{skew}	Duty Cycle Skew ⁽²⁾ (Diff)	—	5	—	—	5	20	—	5	20	—	5	20	ps
V _{PP}	Minimum Input Swing ⁽³⁾	150	—	—	150	—	—	150	—	—	150	—	—	mV
V _{CMR}	Common Mode Range ⁽⁴⁾	-1.3	—	-0.4	-1.4	—	-0.4	-1.4	—	-0.4	-1.4	—	-0.4	V
t _r t _f	Output Rise/Fall Times Q (20% to 80%)	100	225	350	100	225	350	100	225	350	100	225	350	ps

Note 1. Parametric values specified at: 10/100EL16V Series: -3.0V to -5.5V.**Note 2.** Duty cycle skew is the difference between a t_{PLH} and t_{PHL} propagation delay through a device.**Note 3.** Minimum input swing for which AC parameters are guaranteed. The device has a DC gain of ≈40.**Note 4.** The CMR range is referenced to the most positive side of the differential input signal. Normal operation is obtained if the HIGH level falls within the specified range and the peak-to-peak voltage lies between V_{PP} min. and 1V. The lower end of the CMR range varies 1:1 with V_{EE}. The numbers in the spec table assume a nominal V_{EE} = -3.3V. Note for PECL operation, the V_{CMR} (min) will be fixed at 3.3V - |V_{CMR} (min)|.**Note 5.** Specification for packaged product only.

8-PIN MSOP (K8-1)



Rev. 01

Package Notes:

Note 1. Package meets Level 1 moisture sensitivity.

8-PIN SOIC(Z8-1)

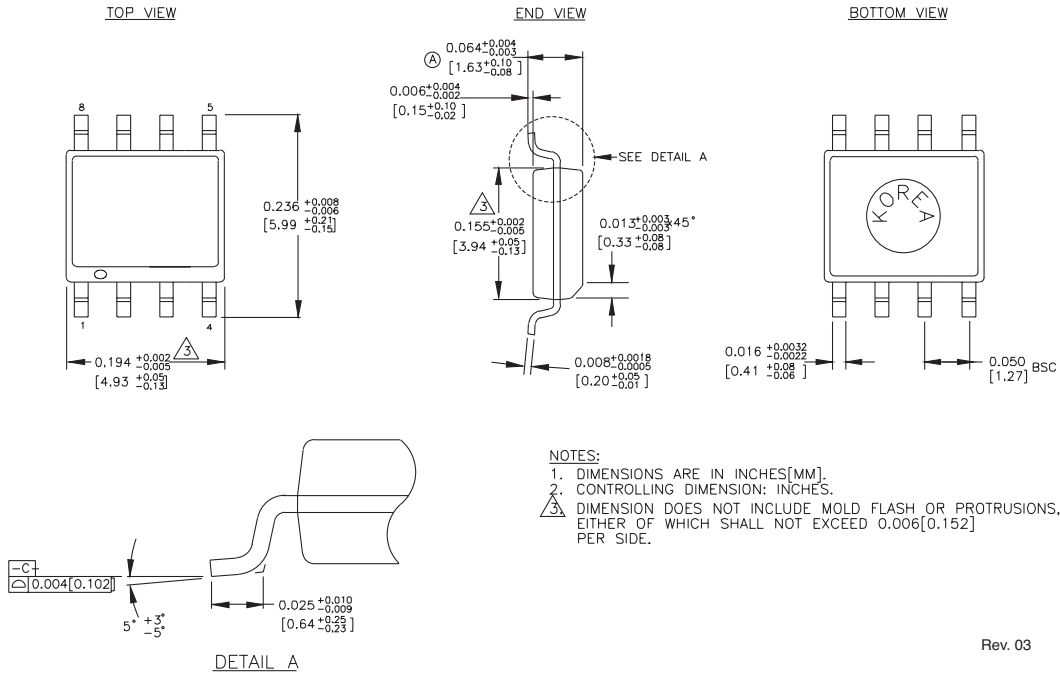

Package Notes:

Note 1. Package meets Level 1 moisture sensitivity.

MICREL, INC. 2180 FORTUNE DRIVE SAN JOSE, CA 95131 USA

TEL + 1 (408) 944-0800 FAX + 1 (408) 474-1000 WEB <http://www.micrel.com>

The information furnished by Micrel in this datasheet is believed to be accurate and reliable. However, no responsibility is assumed by Micrel for its use. Micrel reserves the right to change circuitry and specifications at any time without notification to the customer.

Micrel Products are not designed or authorized for use as components in life support appliances, devices or systems where malfunction of a product can reasonably be expected to result in personal injury. Life support devices or systems are devices or systems that (a) are intended for surgical implant into the body or (b) support or sustain life, and whose failure to perform can be reasonably expected to result in a significant injury to the user. A Purchaser's use or sale of Micrel Products for use in life support appliances, devices or systems is at Purchaser's own risk and Purchaser agrees to fully indemnify Micrel for any damages resulting from such use or sale.

© 2006 Micrel, Incorporated.